

STANLEY

444

A Dovetail
Tongue and Groove
Plane



THE STANLEY RULE & LEVEL PLANT.
THE STANLEY WORKS
NEW BRITAIN, CONN. U.S.A.

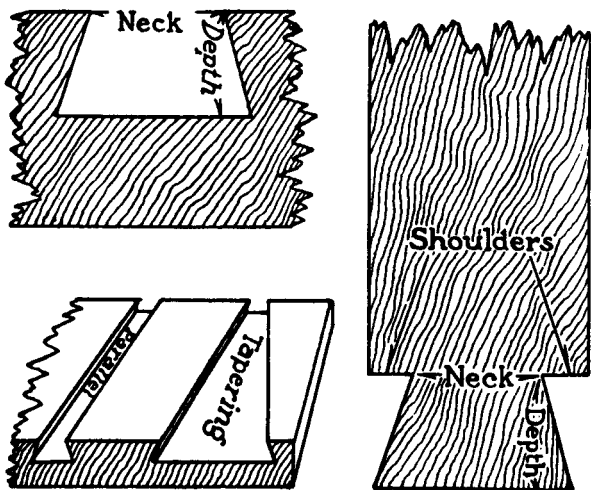

THE DOVETAIL JOINT.

Above are shown the several parts of a DOVETAIL JOINT and the application of the terms NECK, DEPTH, SHOULDER, etc., as used in the instructions for "Laying out," "Making Groove," "Making Tongue."

When making a DOVETAIL JOINT, the first thing for the workman to determine is the width of the NECK and the DEPTH he desires.

GROOVE.

The No. 444 Plane will cut any Dovetail Groove where the width of the neck is more than one-quarter of an inch in width or where the depth of the groove is not more than three-quarters of an inch.

The design of the Plane takes care of the flare which is always twenty degrees, consequently the width of the bottom of the Groove does not have to be taken into consideration when one is laying out the work.

TONGUE.

The neck and depth dimensions of the Tongue are the same as those in the Groove. The two shoulders, however, may be of the same or different widths as desired up to five eighths of an inch each.

Inasmuch as each side of both the Tongue and Groove are cut separately with the No. 444 Plane, it is possible to make the sides of the joints either parallel or tapering, as shown in the above illustration.

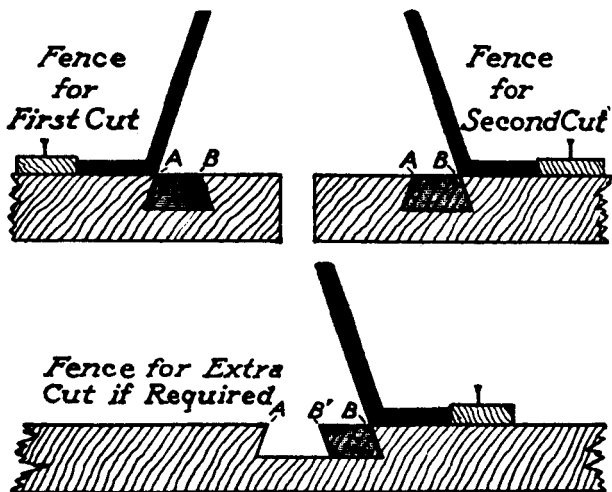

TO LAY OUT.

Having decided upon the width of the neck (A-B) mark two lines showing the edges of the cut, with a knife. Knife lines are more exact than pencil marks, and they will serve to act as guides for one Spur.

A Batten should be nailed on top of the board on which the Groove is to be made. (In the same manner as for making an ordinary Dado.)

To locate Batten, place BEVEL FENCE along the line through A. The other edge is the guide for nailing the Batten. Now make first cut.

In locating the Batten for second cut, place the BEVEL FENCE along the line drawn through B. Then move the Batten, nailing same against the outer edge of Fence, and proceed same as before.

For Grooves of wider neck than five-eighths of an inch, more than two cuts will be necessary. Lay out the lines through A and B to mark the edges of neck required. Lay out line through B' (not over five-eighths of an inch from A) for a second cut, and the distance between B' and B is cut with one or more operations, in the same way as second cut was made, the Fence and Batten being moved outwardly for each cut.

No layout of any kind is required when cutting the Tongue.

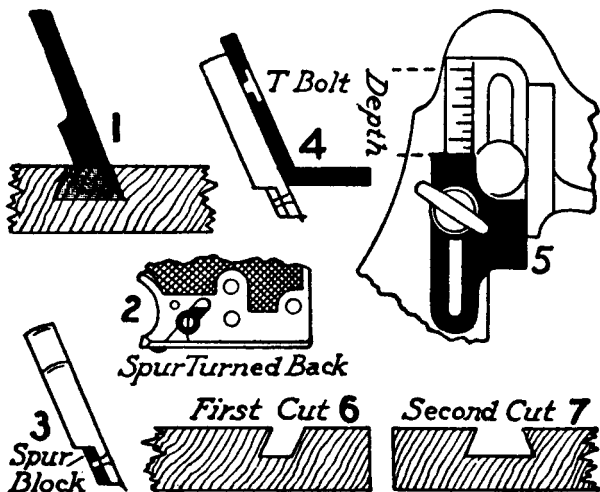

TO MAKE GROOVE.

- 1 Select the widest groove CUTTER which can easily pass through the neck. Place same in the Main Stock and fasten it securely by tightening the cutter thumb screw on top of the Main Stock.
- 2 If the cutter is wider than the runner of the Main Stock, turn back the right hand SPUR on the runner, as shown in illustration above.
- 3 Attach the SPUR BLOCK which will give a spur for the outer edge of the cutter. There are two Spur Blocks furnished with each Plane.
- 4 Hang the BEVELED FENCE to the left side of the Main Stock by slipping same over the "T" bolt in position shown.
- 5 Adjust the DEPTH GAUGE STOP so that the graduation seen (reading from the top) will show the desired depth of the groove.
- 6 The Plane is now ready for the cut and should be placed on the work with the outer edge of the Fence against the Batten, and the left-hand Spur in the knife mark locating the edge of the groove to be cut. Make the FIRST CUT, working the Plane until the stop is reached.
- 7 For the SECOND CUT, turn the work around, change the Batten and proceed in like manner until a smooth bottom to the groove is obtained.

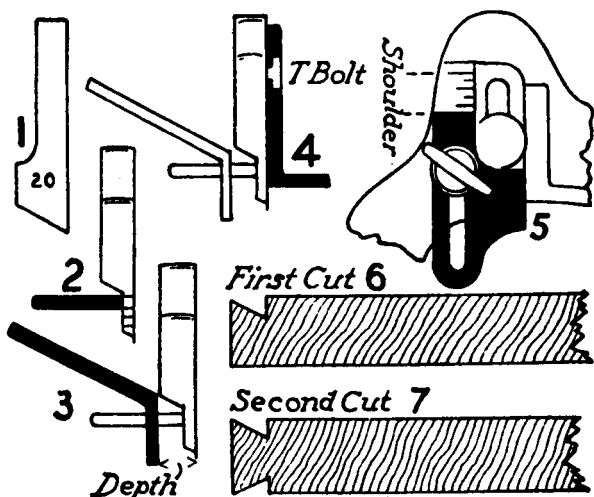

TO MAKE TONGUE.

The Plane as assembled for cutting the groove has to be taken apart before cutting the tongue, as the latter operation is a separate one.

- 1 Insert CUTTER No. 20 in the Main Stock. There is only one tongue cutter—when tongues with small depths are made it will overhang.
- 2 Screw the FENCE ARMS into the right side of the Main Stock. The upper holes being used for small tongues and the lower for large.
- 3 Put the BEVELED FENCE on the arms in the position shown in the cut and fasten it to the arms so that the distance from the INSIDE face of the Fence to the cutting edge of the left-hand Spur on the runner of the Main Stock will be equal to the depth of the groove already cut.
- 4 Hang the SQUARE FENCE over the "T" bolt as illustrated above.
- 5 Adjust the DEPTH GAUGE STOP so that graduation shown (reading from the top of scale) will equal the shoulder required for first cut.
- 6 The Plane being assembled is now ready to make the FIRST CUT.
- 7 If the two shoulders are equal, the work may be turned over and the second shoulder cut, but if the second shoulder is not equal to the first, the depth stop should then be reset for the SECOND CUT.

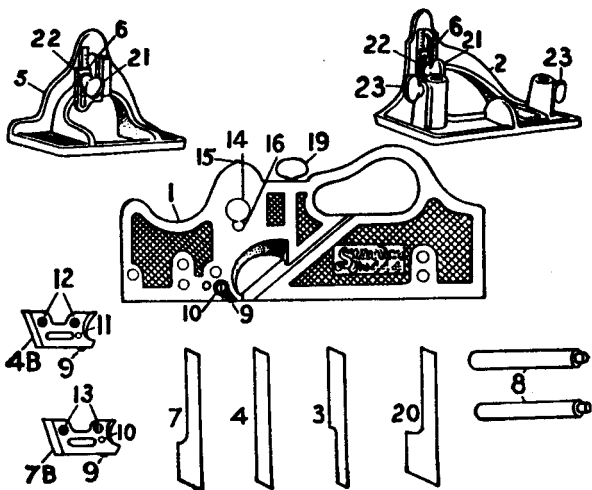

NO. 444 PLANE.

This unique plane is packed with all its parts complete in a neat wooden box, $10\frac{1}{4} \times 5\frac{1}{4} \times 5$ inches and weighs complete 6 lbs.

Parts marked * are not assembled when packed. Check up the contents of box with the list below. Parts for repairs when required should be ordered by stating both name and number.

LIST PRICE \$14.70

No.			List Price
1	* Main Stock	Each	\$5.00
2	* Beveled Fence	"	2.50
5	* Square Fence	"	2.00
3	* Groove Cutter (small)	"	.40
4	* Groove Cutter (medium)	"	.50
7	* Groove Cutter (large)	"	.60
4-B	* Spur Block for No. 4 Cutter	"	.40
7-B	* Spur Block for No. 7 Cutter	"	.60
20	* Tongue Cutter	"	1.00
8	* Fence Arms (two)	Per Pair	.50
9	Spurs & Spur Screws Nos. 10, 11, 12 and 13	" Doz.	.50
14-15	"T" Bolt and "T" Bolt Set Screw	Each	.20
16	Slide Slot Stop Screw	"	.20
19-21-23	Thumb Screws	"	.20
6	Depth Gauge Stop Plate	"	.20
22	Depth Gauge " Thumb Screw Washer	"	.10

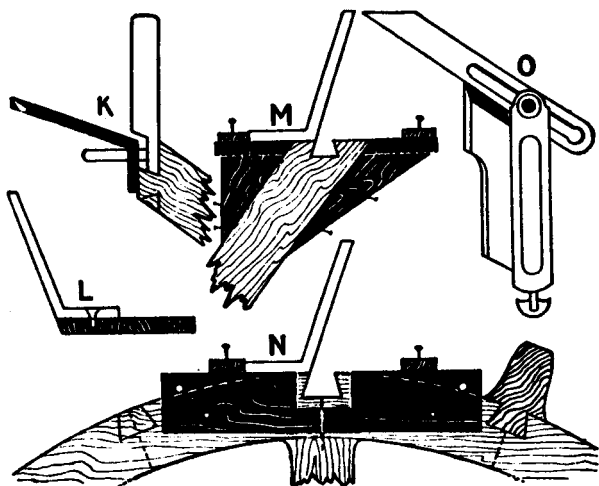

SOME 444 AIDS.

WOODEN SOLE PLATES FOR FENCES.

The countersunk holes in the fences are for screwing on wooden sole plates if wanted, (see cut L). If sole plates are used, allow for extra thickness when setting the depth gauge stop.

GRINDING THE CUTTERS BY BEVEL.

Tongue and Groove cutters must be ground on the same skew, the angle of which is $7\frac{1}{2}$ degrees. Set a bevel at the correct angle by means of the line marked on the cutter box, then lay the side of the cutter (with bevel of cutting edge up) along the bevel handle and the cutting edge should be true to the blade of the bevel (see cut O).

BEVELED AND CIRCULAR SURFACES.

When joints are made on beveled or circular surfaces, it is necessary to build up proper supports to hold the hattern and give a bearing surface to the Plane when cutting the groove. This can be done by fastening on side pieces (see cut M), or where a number of similar joints are to be made by clamping on a jig (see cut N). When cutting the tongue on a beveled surface it is impossible to use the square fence as a gauge for the shoulders. The tongue must be marked out on the work—the bevel fence set on the arms for depth and the shoulder obtained by working to the line. (see cut K).

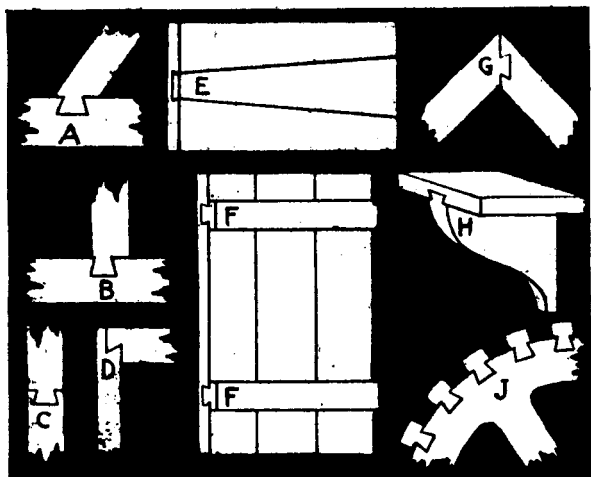

SOME 444 WORK.

- A Dovetail tongue and groove joint with the groove cut in the regular manner, and the tongue cut on a bevel, used for supports.
- B Dovetail tongue and groove joint with unequal shoulders, or a joint with a regular groove, but where the tongue is offset.
- C Dovetail tongue and groove joint as can very often be conveniently used when one is forming an end to end timber match.
- D Dovetail tongue and groove half joint, frequently used by carpenters to a very good advantage in concealed nail work.
- E Dovetail tongue and groove joint as applied to a flush batten, where used in strengthening side thin boards across the grain.
- F Dovetail tongue and groove joint as it is very often used to construct a batten on doors made of several boards, etc.
- G Dovetail tongue and groove joint where both the groove and tongue are cut on a beveled surface, making a strong corner.
- H Dovetail tongue and groove joint shown in one of its most useful applications, that of a bracket supporting a shelf.
- J Dovetail tongue and groove joint as applied to the setting of gear teeth around the outer rim of any gear pattern.

PRINTED IN U.S.A.